



Toilet and Shower Cubicle Installation Guide

General Information

The procedures outlined in the following pages apply to all Cubicle Solutions product ranges. The procedures outlined refer to typical fittings and dimensions and should therefore be viewed as a guideline only. Where dimensions differ to the typical i.e. where dividers, doors, fascias etc are larger than normal; additional mounting brackets/support legs/hinges may be required to complete the installation.

There are also significant differences between the fitting procedures for Melamine Faced Chipboard (MFC), and Solid Grade Laminate (SGL). These differences are clearly defined within the Installation instructions detailed in the following pages.

Contents

Page	Description
2	Cubicle Fitting Procedure
3	Hardware
4	Mounting Bracket Fitting Instructions (All cubicles with the exception of SGL)
5	Mounting Bracket Fitting Instructions (SGL Only)
6	Support Leg Fitting Instructions
7	Hinge Assembly Fitting Instructions (All cubicles with the exception of SGL)
8	Hinge Assembly Fitting Instructions (SGL Only)
9	Atlanta Latch Fitting Instructions (See Important Notes before attempting to fit the latch)

Cubicle Fitting Procedure

1. Using a plumb line or spirit level, align and mark the required position of the divider on the rear wall.
2. Secure a mounting bracket to the wall at the required centre line height of the divider (see Fig 1) as detailed on page 4.
3. Secure two further mounting brackets to the wall at approximately 150mm from the top and bottom of the required divider position (see Fig 1).
4. Align the divider with the mounting brackets and secure all three brackets to the divider as detailed on page 4.
5. Secure the support leg as detailed on page 6.
6. Carefully measure the distance from the mounted divider to the required position for the second divider and proceed as detailed at paras 1 to 5 above.
7. Repeat paras 1 to 6 above to fit further dividers as required.
8. Secure three mounting brackets to the fascia, again at the centre and at approximately 150mm from the top and bottom of the fascia in a similar manner to the divider (see Fig 2) as detailed on page 3. *Be aware that in certain configurations the fascias may be offset.*
9. Align the fascia and divider and secure all three mounting brackets to the divider as detailed on page 4.
10. Repeat paras 8 and 9 as required to mount all fascias to their corresponding dividers.
11. Measure the overall length of the cubicle range and cut the headrail as required. If more than one headrail is required, ensure that the two headrails meet at the centre point of a fascia. Fit the headrail by drilling 2 suitably sized holes through the headrail vertically into the top of each fascia. Secure the headrail to each fascia with 2 screws.
12. Fit door hinges as detailed on page 8.
13. Fit Indicator latches to doors as detailed on page 9.
14. Repeat paras 12 and 13 for all doors as required.
15. Fit the coat hook to the rear of the door using the screws provided.

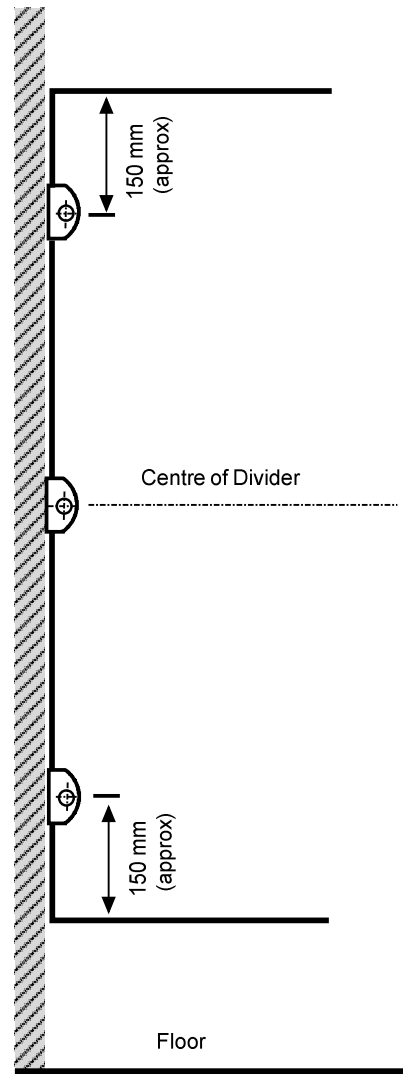

Fig 1 Fitting Wall Mounting Brackets

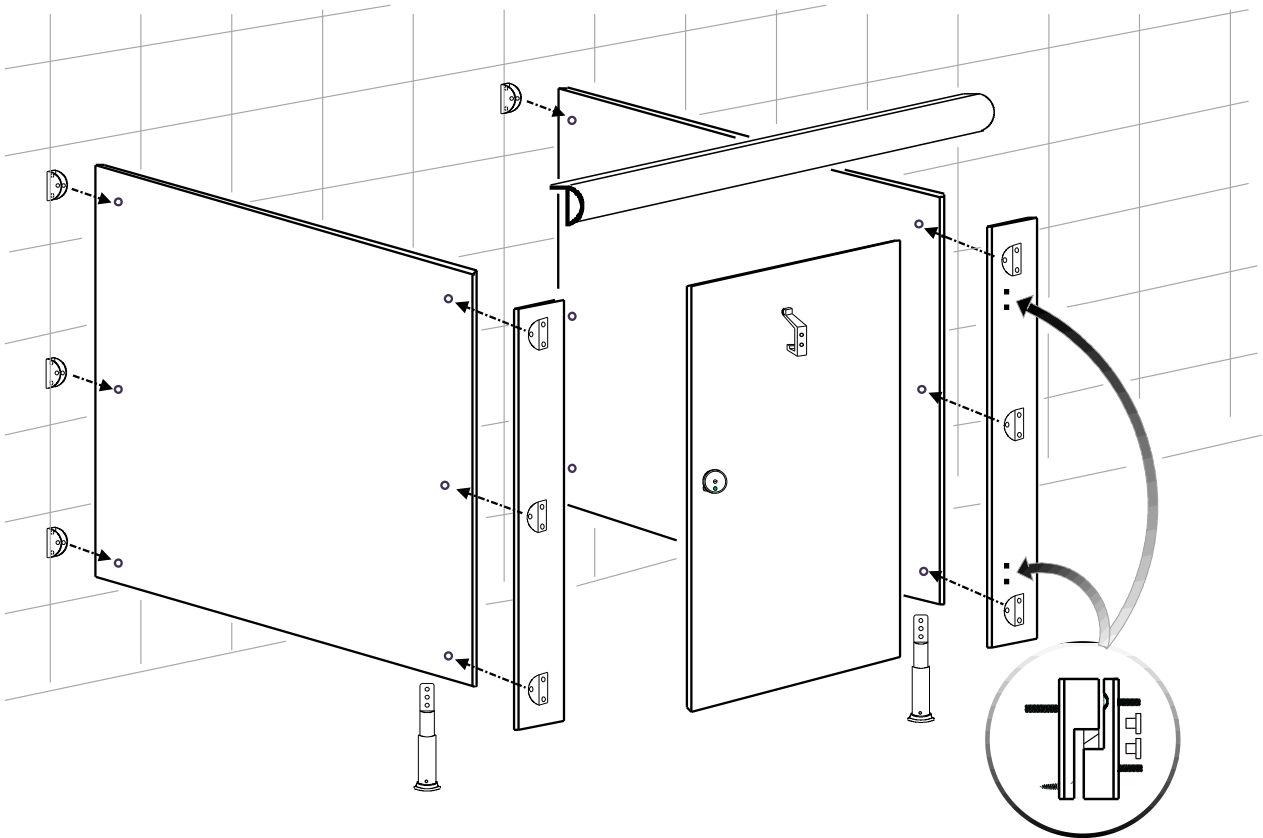

Fig 2 Typical Toilet Cubicle Configuration

NOTE: The hinge illustrated above is for all cubicles with the exception of SGL. The SGL hinge is detailed and illustrated on page 8

Hardware

The following items of hardware are typically provided on an 'as required' basis with all our cubicles:

- Mounting Brackets – Supplied with all required fasteners.
- Support Legs - Supplied with all required fasteners.
- Hinge Assemblies - Supplied with all required fasteners.
- Atlanta Latches – One per cubicle. Supplied with all required fasteners and fitting template.
- Coat Hooks - One per door. Supplied with all required fasteners.
- Headrail- Supplied at sufficient length for cubicles. No fasteners provided.

Mounting Bracket Fitting Instructions (All cubicles with the exception of SGL)

Mounting the Bracket to the Wall

1. Mark the two holes on the wall at the required height.
2. Drill the holes @ $\varnothing 5.5\text{mm}$ to a depth of 50mm.
3. Secure the brackets using the screws and rawl plugs provided.

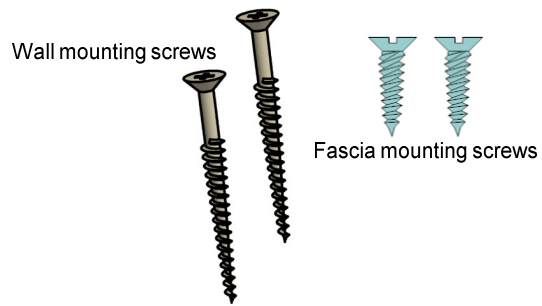

Mounting the Panel to the Wall Bracket

1. Position the panel in the brackets.
2. Drill through the brackets using a $\varnothing 9.5\text{mm}$ drill.
3. Secure the panel to the brackets using the T Nut and Allthread provided.

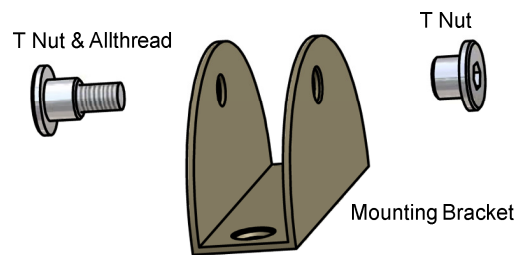

Mounting the Bracket to the Fascia

1. Mark the two holes on the fascia at the required height.
2. Secure the bracket to the fascia using the screws provided. *Be aware that in certain configurations the brackets may need to be offset from the vertical centreline of the fascia.*
3. Align the fascia to the panel and mount the bracket to the panel as detailed under **Mounting the Panel to the Wall Bracket** above

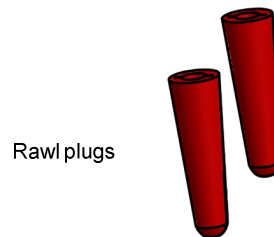

Mounting Bracket Fitting Instructions (SGL Only)

General Information

Two types of Mounting Brackets are supplied for use with SGL cubicles:

- A Wall to Panel (Divider) Mounting Bracket which is similar to the Mounting Bracket illustrated on page 4. The fitting instructions for which are detailed under **Mounting the Bracket to the Wall** and **Mounting the Panel to the Wall Bracket** below.
- A Panel to Fascia type Mounting Bracket is also supplied. This Mounting Bracket is illustrated (right) and detailed under **Mounting the Panel to the Fascia** below.

Mounting the Bracket to the Wall

1. Mark the two holes on the wall at the required height.
2. Drill the holes @ $\varnothing 5.5\text{mm}$ to a depth of 50mm.
3. Secure the brackets using the screws and rawl plugs provided.

Mounting the Panel to the Wall Bracket

1. Position the panel in the brackets.
2. Drill through the brackets using a $\varnothing 9.5\text{mm}$ drill.
3. Secure the panel to the brackets using the T Nut and Allthread provided.

Mounting the Panel to the Fascia

1. Mark the two holes on the fascia at the required height.
2. Drill through the fascia using a $\varnothing 9.5\text{mm}$ drill and secure the bracket to the fascia using the screws provided. *Be aware that in certain configurations the brackets may need to be offset from the vertical centreline of the fascia.*
3. Align the fascia to the panel and mount the bracket to the panel as detailed under **Mounting the Panel to the Wall Bracket** above

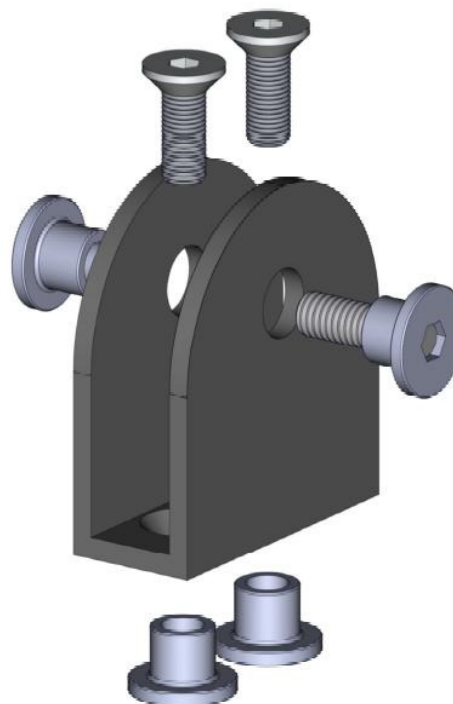

Support Leg Fitting Instructions

- Mark all holes/centre line positions as accurately as possible.
- Take care not to damage hardware or chip powder coatings during installation.

1. Mark off the vertical centre line of the support leg onto the front edge of the divider, ideally this should be within 250mm from the front edge.

2. Loosen the retaining screw in the leg Shroud and lift up the shroud to access the adjuster mechanism. Adjust the block up into the support as far as it will allow.

3. Offer up the support to the divider and mark out the hole position on the centre line.

4. Drill through the divider using a $\varnothing 9.5\text{mm}$ drill.

5. Fix the support to the divider using the M6 T nuts and M6 Allthread.

6. The divider can now be mounted to the wall, ensuring that the front edge is supported by the use of packing pieces.

7. Once the divider is secure, the support block can be adjusted to floor level, taking full support of the divider.

8. Using a $\varnothing 5.5\text{mm}$ masonry drill, drill through the block, following the machined angle, to a depth of 50mm.

9. Fit the red rawl plugs and secure the Support leg to the floor using the No8 x 2" woodscrews.

10. The shroud can now be lowered to the block and secured using the retaining screw.

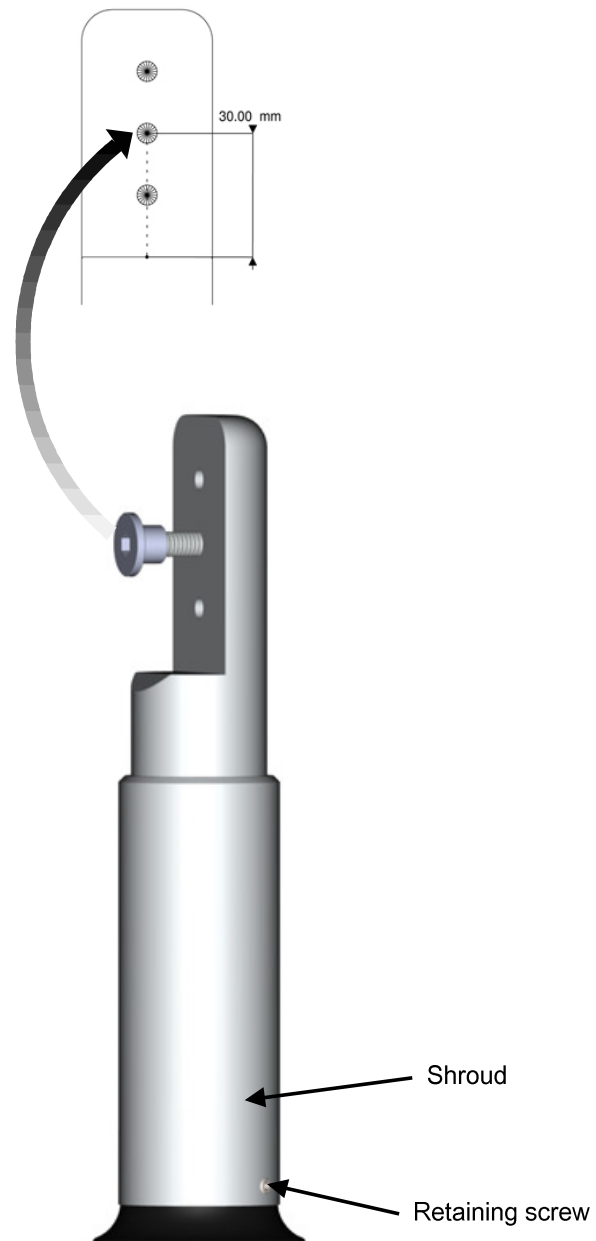

Hinge Assembly Fitting Instructions (All cubicles with the exception of SGL)

- The hinges are through fixed to the back of the fascia and face fixed to the edge of the door.
- The edge of the door and fascia should be pre-drilled to the dimensions shown below.
- To ensure trouble free operation of the hinges it is extremely important to mark and fit as accurately and vertically as possible to prevent the risers from binding when fitted.

1. To dismantle the hinge, remove the M5 x 10 M/C head screw and pull the hinge apart.

2. Align the hinges to the door and fascia and secure with the M6 T nuts and M6 Allthread and Countersunk screw.

3. When fitting, ensure the hinge pin is pointing downwards.

4. Lift the door into place and test for smooth operation. The hinges are supplied in the 'door open' position.

5. When fully satisfied with the operation of the hinge, secure the M5 x 10 M/C head screw (removed at para 1 above), to the hinge pin.

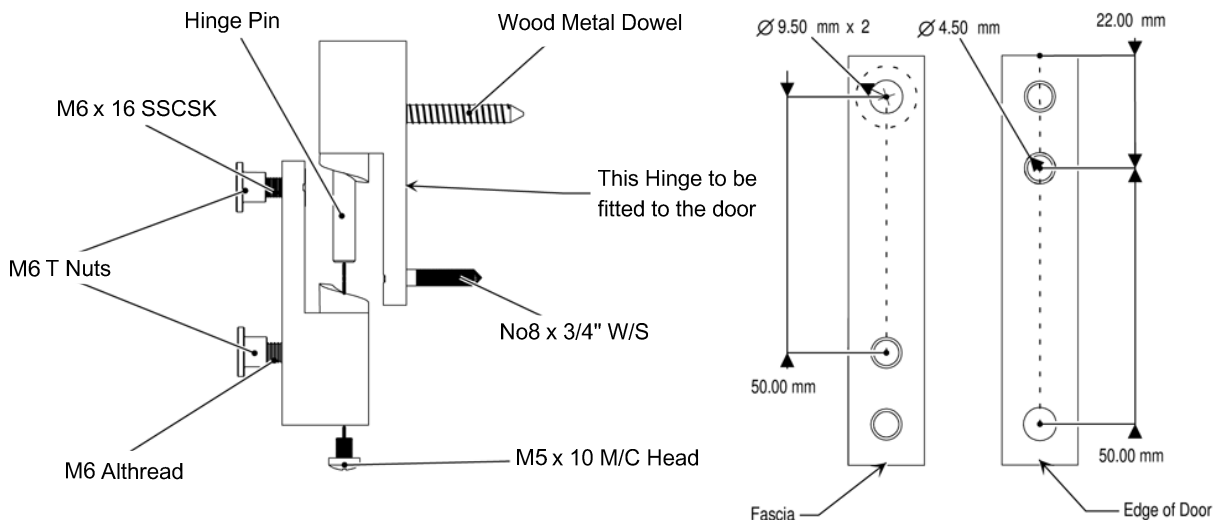
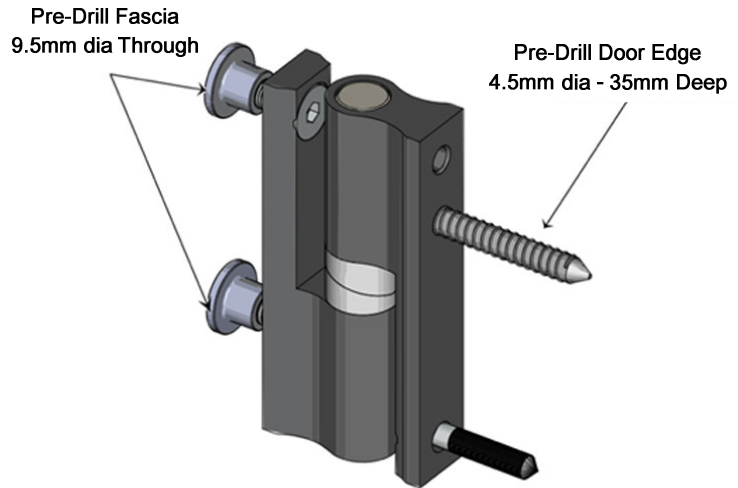

Hinge Assembly Fitting Instructions (SGL Only)

- The hinges are through fixed to the fascia and wrap around the door.
 - To ensure trouble free operation of the hinges it is extremely important to mark and fit as accurately and vertically as possible to prevent the risers from binding when fitted.
1. To dismantle the hinge, remove the M5 x 10 M/C head screw and pull the hinge apart.
 2. Position the wrap around hinge on the door, mark the holes and drill through using a $\varnothing 9.5\text{mm}$ drill.
 3. Secure the wrap around hinge to the door using the M6 T Nuts and M6 Allthreads provided.
 4. Position and secure the fascia hinge.
 5. During fitting, ensure the hinge pin is pointing downwards.
 6. Lift the door into place and test for smooth operation. Hinges are supplied in the 'Door Open' position.
 7. When fully satisfied with the operation of the hinge, secure the M5 x 10 M/C head screw (removed at para 1 above), to the hinge pin.

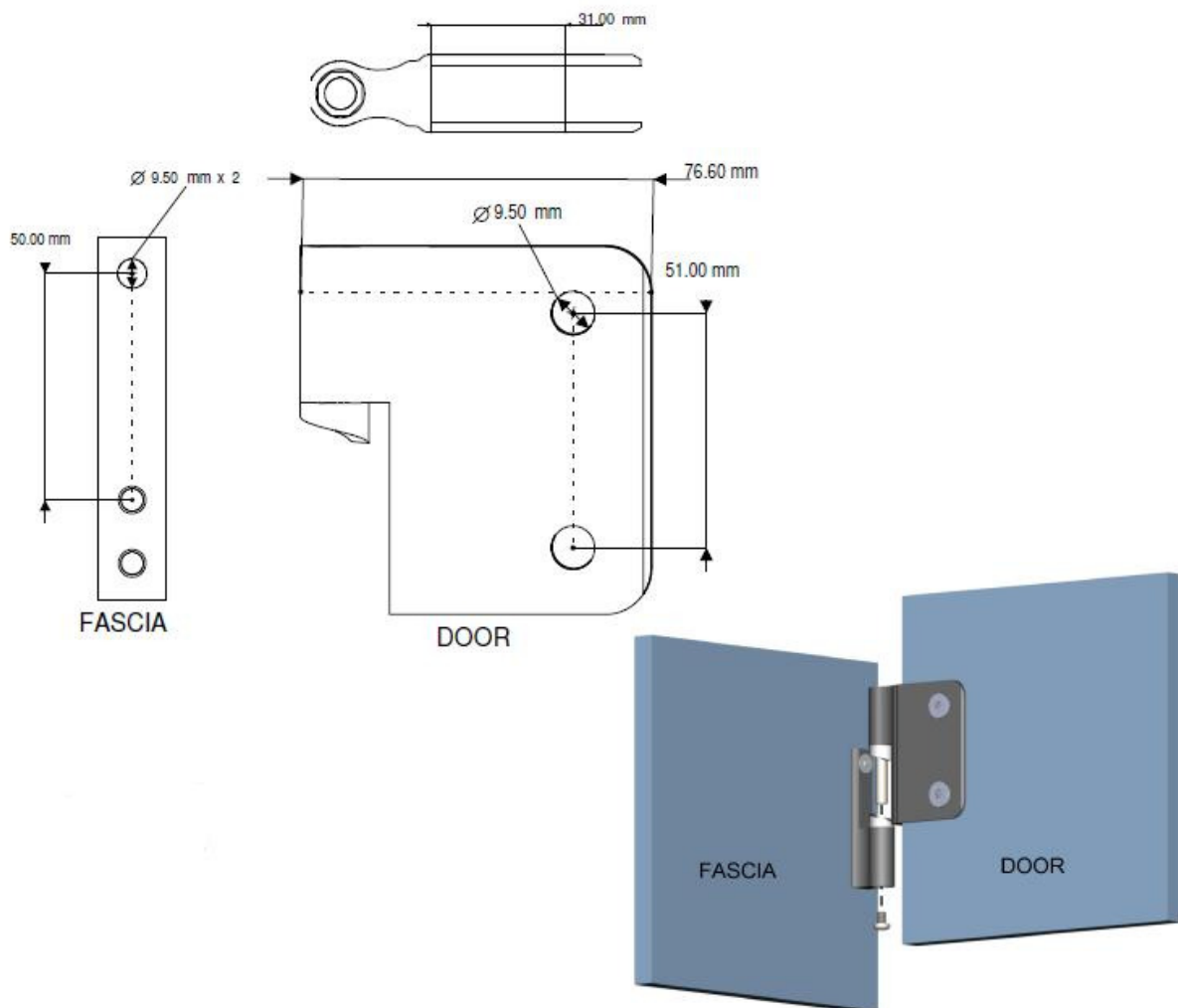

Atlanta Latch Fitting Instructions

IMPORTANT NOTES:

1 THE DOOR LEAF MUST BE HUNG PRIOR TO FITTING THE ATLANTA LATCH.

2 IF THE DOOR OPENS INWARDS THE LATCH MUST BE FITTED TO THE FASCIA. IF THE DOOR OPENS OUTWARDS, THE LATCH MUST BE FITTED TO THE DOOR.

1. Using the template provided, mark out the hole positions and drill the holes.
2. Remove the M4 x 16 screws and dismantle the latch.
3. Ensure the Signal and Knob assemblies are in the closed position.
4. Position the AT Face Plate against the door.
5. Align the AT Knob assembly to the Face Plate.
6. Secure the two assemblies using the M4 x 16 screws.
7. Ensure the Face Plate is positively and securely located.
8. Ensure there is free movement of the latch.
9. Ensure that the Signal indicates GREEN when open and RED when closed.
10. Fit the screw covers.
11. Fit buffers to the top and bottom of the door.

